

# The Potential Consequences of Climate Variability and Change

# WATER

**Here, There, Everywhere**



**AN ACTIVITY RESOURCE  
FOR TEACHERS**

***Responding to National  
Education Standards in:***

- ***English Language Arts***
- ***Geography***
- ***Mathematics***
- ***Science***
- ***Social Studies***

---

**T**his learning activity was developed to examine the potential impacts of climate variability and change. Each activity is part of an overall series entitled *The Potential Consequences of Climate Variability and Change*, which includes 1–12 teacher resources. Twelve modules (10 printed and 2 online resources) comprise the set and are presented below:

### **OVERVIEW**

- Too Many Blankets (Grades 1–4)
- Global Balance (Grades 5–12)

### **AGRICULTURE**

- El Niño (Grades 5–8)  
This activity is provided in an online format only and is available at <http://ois.unomaha.edu/casde/casde/lessons/Nino/teacherp.htm>.
- The Great American Desert? (Grades 9–12)  
This activity is provided in an online format only and is available at <http://ois.unomaha.edu/casde/casde/lessons/grass/teacherp.htm>.

### **COASTAL AREAS**

- What Could a Hurricane Do to My Home? (Grades 5–8)
- What Is El Niño? (Grades 5–8, 9–12)
- Coral Reefs in Hot Water (Grades 9–12)

### **FORESTS**

- A Sticky Situation (Grades 5–8)
- Planet Watch (Grades 9–12)

### **HUMAN HEALTH**

- Beyond the Bite: Mosquitoes and Malaria (Grades 5–8, 9–12)
- Climate and Disease: A Critical Connection (Grades 9–12)

### **WATER**

- Here, There, Everywhere (Grades 7–8, 9–12)

The development of the activities was sponsored by the National Aeronautics and Space Administration and the Environmental Protection Agency, in support of the US Global Change Research Program. The Institute for Global Environmental Strategies implemented the effort. For more information, see <http://www.strategies.org>. For additional resources, please visit <http://teach.earth.com>—Resources for Teaching and Learning about Earth System Science.

---

# Climate Variability & Change

## **WATER**

---

**Authored by:**

Andrew Sajor, Classroom Teacher, Peru School District,  
Plattsburgh, NY.

**Prepared by:**

Stacey Rudolph, Senior Science Education Specialist, The  
Institute for Global Environmental Strategies, Arlington, VA.  
Graphic Design by Susie Duckworth.

## **THREE ACTIVITIES**

# **Here, There, Everywhere**



### **CONTENTS**

Grade Levels; Time Required; Objectives; Disciplines Encompassed; Prerequisite Knowledge: Teacher .....	2
Prerequisite Knowledge: Students; Background: Activity One; Background: Activity Two .....	3
Background: Activity Three; Key Terms and Concepts; Suggested Reading/Resources .....	4
Activity One: Pan Evaporation, Relative Humidity and Daily Minimum/Maximum Temperatures.....	5
Student Activity One Lab Sheet .....	7
Activity Two: Minimum and Maximum Temperatures and Yearly Temperature Averages .....	11
Student Activity Two Lab Sheet .....	13
Activity Three: Changes in Salinity Due to Glacier Movement.....	17
Student Activity Three Lab Sheet .....	19
Appendix A: Bibliography .....	21
Appendix B: Assessment Rubrics & Answer Key .....	22
Appendix C: National Education Standards .....	25
Appendix D: Associated Lab Exercises.....	28
Appendix E: Information Associated with Activity Three .....	34

# Here, There, Everywhere



**T**his curriculum packet contains three activities that explore the potential impact of climate variability and change on Earth's most abundant resource, water. Although each activity is designed to tap specific skills and knowledge to yield scientific results, the broader intent is to stimulate thought about the long-term impacts of a warmer planet.

## **GRADE LEVELS**

Grades 7–8; 9–12

## **TIME REQUIRED**

Six to eight 40-minute class periods. Additional time must be allowed for students to set up, maintain, and collect data-generating devices (this will be conducted at various times during the day).

## **OBJECTIVES**

Through their participation in the following three activities, students will:

- Observe pan evaporation;
- Describe how evaporation rate relates to air temperature and relative humidity;
- Explain how water vapor can affect global temperatures;
- Analyze regional atmospheric variations for various years across the United States;
- Interpret the effect of fresh water intrusion on a saltwater estuary environment;
- Apply Internet research skills;
- Develop sampling protocols that allow students to obtain data that will help relate their knowledge to a global scheme; and
- Share data to achieve a global perspective.

## **DISCIPLINES ENCOMPASSED**

- Earth System Science
- Ecology
- Environmental Science
- Mathematics
- Meteorology
- Technology

## **PREREQUISITE KNOWLEDGE: TEACHER**

- Just as the blood in our bodies distributes our heat and energy, water on Earth performs much the same function. Moving heat from the tropics to the Arctic regions by ocean and atmospheric currents, water's high specific heat helps keep our planet in thermal balance. If your students have not done experiments examining water's special properties, it would be beneficial to do those before proceeding (see Appendix D).
- For water to change state, large quantities of energy must be exchanged. When liquid water becomes vapor, it must absorb 540 calories per gram of water. Conversely, when water vapor becomes liquid, it must give up those 540 calories of heat energy. Liquid water will evaporate more easily when the Earth's atmosphere is warmer, which means the atmosphere can transfer more energy from one area to another when it is warming. When the atmosphere has more water in it, it cools more slowly. This is because the water in the atmosphere gives up large quantities of energy as it cools. That energy is released to the air, slowing the air's rate of cooling. So, if global temperatures are rising, liquid water will more easily evaporate because it has more energy. If the atmosphere contains more water (which blocks the loss of heat from the Earth and the

atmosphere), we should see smaller differences between minimum and maximum temperatures due to the latent heat of water.

- While each of the following activities are intended to study the potential consequences of climate variability and change, they were not intended to link scientific concepts.

### ■ Introduction to Activities: A Pause for Thought

For humans to live in harmony with nature, we need to understand it. By studying our environment, we can apply the knowledge we have to evaluate the health of the planet and discuss potential impacts. It is important to remember that these potential impacts are not black and white; there are many variables that must be examined.

Due to the complexities of the issues, upper middle and high school students might best spend time exploring the physical processes and then brainstorm on the possible consequences. We must keep in mind Newton's third law of motion: for every action there is an equal and opposite reaction. To that end, the following activities explore some of the elements that are related to the potential impacts of climatic change. These are simple relationships that should help students see potential problems that can arise from a changing climate. The hope is that students will come away from these activities with an awareness that environmental change is an issue that requires constant research and questioning.

### **PREREQUISITE KNOWLEDGE: STUDENTS**

Students must have the following skills and knowledge to complete these activities:

- An understanding of the water cycle.
- A general understanding of remote sensing.
- Basic algebra.
- Graphing skills.
- Internet knowledge.

### **BACKGROUND: ACTIVITY ONE**

- The rate at which water evaporates into the atmosphere is a function of temperature, relative humidity, wind speed, and atmospheric stability.
- Warmer air temperatures will support more water vapor in the air.
- Relative humidity is the percentage of water vapor in the air compared to the amount of water vapor the air can hold at the same temperature and pressure.
- If the air in contact with the surface is very calm and very stable, little evaporation will occur, regardless of atmospheric temperature and humidity. On the other hand, a strong wind and low atmospheric stability will cause high evaporation rates even when the air temperature is low and the relative humidity is high.
- The data collected in this experiment is loss of mass in the pan. Because this is measured in grams, the evaporation rate can be calculated as  $G/M^2$  (grams per square meter). Since 1,000 grams is equal to 1 liter, the evaporation rate can then be converted to  $L/M^2$  (liters per square meter).

### **BACKGROUND: ACTIVITY TWO**

- Students should read the following Web-based articles as an introduction to this topic. These Web sites contain related links that can be explored, depending on the students depth and previous knowledge.
- "Analysis of Trends in the U.S. and the Former U.S.S.R. Pan Evaporation:"  
[www.ncdc.noaa.gov/ol/climate/research/ogp/papers/peterso2.htm](http://www.ncdc.noaa.gov/ol/climate/research/ogp/papers/peterso2.htm)
- "Global Warming" (a starting point for discussions on global warming, greenhouse gases, the hydrologic cycle, and natural variability):  
[www.ncdc.noaa.gov/ol/climate/globalwarming.html#INTRO](http://www.ncdc.noaa.gov/ol/climate/globalwarming.html#INTRO)

**BACKGROUND: ACTIVITY THREE**

- Students should have an understanding of freshwater/saltwater estuary environments.
- Students should be able to use/read a DC milliamper meter.
- <http://edcwww.cr.usgs.gov/earthshots/slow/tableofcontents>  
To download images, scroll down the right side of the page and under “Water,” click on “Hubbard Glacier, Alaska.” Then click on the image, save it to a folder, and open as a jpg offline.
- Refer to Appendix E.

**KEY TERMS AND CONCEPTS**

The following terms and concepts will be presented in the following text and activities:

Ambient  
 Calories  
 Conduction  
 Convection  
 Diurnal  
 Ecosystem  
 Energy balance  
 Energy transfer  
 Evaporation  
 Freshwater/saltwater estuary environment  
 Global warming  
 Greenhouse gas  
 Latent heat  
 Phase changes  
 Radiation  
 Relative humidity  
 Remote sensing  
 Salinity  
 Spatial  
 Specific heat  
 Specific humidity  
 Temporal

**SUGGESTED READING/RESOURCES**

- USGS Earthshots  
<http://edcwww.cr.usgs.gov/earthshots/slow/Hubbard/Hubbardtext>  
<http://edcwww.cr.usgs.gov/earthshots/slow/Hubbard/PERSpaper1985>
- Pan Evaporation Decreases  
<http://www.ncdc.noaa.gov/ol/climate/research/ogp/papers/peterso2.html>
- Irrigation Scheduling: Evaporation Pans Still Work!  
<http://www.montana.edu/~wwwpb/ag/bauder21.html>
- July Global Surface Mean Temperature Anomalies  
[http://www.ncdc.noaa.gov/images/climate/research/1998/anomalies/triad\\_Pg.gif](http://www.ncdc.noaa.gov/images/climate/research/1998/anomalies/triad_Pg.gif)
- Global Temperature (meteorological stations)  
<http://www.giss.nasa.gov/research/observe/surftemp/1998.fig1.GIF>
- Temperature Anomaly (°C)  
<http://www.giss.nasa.gov/research/observe/surftemp/1998.fig2.GIF>

## ACTIVITY ONE

# Pan Evaporation, Relative Humidity, & Daily Minimum/Maximum Temperatures

This activity will show students how to determine rate of evaporation and the atmospheric factors that can affect this rate.

### **MATERIALS**

- Digital balance or triple beam balance (3 kilograms) or metric ruler in millimeter graduations and a spirit level
- Two stainless steel or galvanized pan(s) (at least 25 centimeters x 25 centimeters x 6 centimeters)
- Two 2-quart containers
- A shading device (if necessary)
- Barograph (or barometer), two if possible
- Hydrograph (or hygrometer), two if possible
- Thermograph (or thermometer), two if possible
- Anemometer, two if possible
- 2 rain gauges
- Water
- Internet access (optional)
- Graph paper

### **PROCEDURE**

The following method should yield acceptable results in place of setting up a standard pan evaporation system (4 feet in diameter, 10 inches deep).

#### **Step 1**

Find a location in an open area outside where the apparatus can be set up. Pans are generally set up on an open field of mowed grass on a 6 inch-high wood platform.

#### **Step 2**

Have students determine the surface area of the pan in square centimeters and divide into 10,000. The quotient will later be used to determine the evaporation rate per square meter. Have them write their answers on the enclosed *Student Activity One Lab Sheet*.

#### **Step 3**

Students should fill the two 2-quart containers with tap water and allow it to get to ambient temperature.

#### **Step 4**

Have students then fill each pan with the ambient water and determine the total mass of each. Record the values. If you are using the measurement method, students must be sure that the pan is level and they must measure water depth from the same location each time. When using the measurement method, students will need to determine the volume of water that is equal to a change in 1 millimeter of depth (Pan length in centimeters times width in centimeters times 0.1 per millimeter of difference will equal millimeters of water evaporated.) Students should set one pan up unsheltered and the other in the shade or under a shade device. Place a rain gauge, barograph (or barometer), hydrograph (or hygrometer), thermograph (or thermometer), and anemometer next to each pan.

#### **Step 5**

Because of temporal and spatial discrepancies, if it is feasible have students set up multiple locations to examine the impact location has on the results. Generally, the diurnal sampling rate is four times a day. Establish a schedule, with student teams assigned to collect data at certain times of the day. This will require students to coordinate their schedules with each other and other school responsibilities. The schedule should include data collection before, during, and after school. As part of their data collection, students will:

- Find the original mass of the filled pan;
- After a period of time (determined by the established schedule), re-mass (or re-measure) the contents of the pan and determine the difference. This is the amount of water that has returned to the atmosphere;

- Multiply the missing mass by the number arrived at in Step 2, which will give the evaporation rate per square meter; and
- Divide this figure by the time elapsed between measurements to determine the pan evaporation rate per hour. If there was precipitation during the period, students must factor in the rain gauge reading to the uncovered pan results. (*NOTE: Even when there is precipitation, there can often be evaporation.*)

### Step 6

During the measurement period, students should record the temperature, pressure, wind speed, and relative humidity for the same time. If they do not have the ability to make these readings, students can either search the National Weather Service Web site for their local data, or contact local news sources. There are also many college and university Web sites that have links to satellite imagery of atmospheric water vapor, and images could be downloaded and archived for future reference and correlation.

### Step 7

Have students compare the evaporation rate with the local average temperature, pressure, wind speed, and relative humidity for the corresponding period. This is a valuable data-collection exercise. Students should do as many of the comparisons as possible and graph the results.

### Step 8

Complete the questions on the *Student Activity One Lab Sheet*.

## CONCLUSION

- Discuss with students the changes in the rate of evaporation and possible causes and effects of these changes.
- Ask the students where else they should set up pans to study evaporation rates, and what they would expect to find.
- Discuss with students how a change in global temperature could effect evaporation rates.

## EXTENSIONS

1. Have students determine other locations to place pans and then run the investigation again.
2. Divide the students up into independent research groups. Have these groups research (on the Internet, in the library, by interviews, or any other method) what would happen to the evaporation rate if global temperatures increased. How would this effect sea level, coastal communities, glacial ice, or plant and animal populations?
3. Run the investigation again using salt water. Compare the results to your original investigation.
4. Research greenhouse gases. What are they? Where do they come from? How do they affect global temperatures?



---

**Student Activity One Lab Sheet**  
**PAN EVAPORATION, RELATIVE HUMIDITY & DAILY MINIMUM/MAXIMUM TEMPERATURES**

---

Name \_\_\_\_\_

*Answer the following questions in complete sentences where appropriate. Show ALL work and include ALL labels:*

---

1. What is the surface area of the pan in square centimeters?



---

2. Divide the surface area by 10,000. This quotient will be used in a calculation for Step 5.



---

3. Location and total mass of sheltered pan.



---

4. Location and total mass of unsheltered pan.



5. Measurements (remember to show ALL work and include ALL labels):



<b>Date and time</b>	
<b>Temperature</b>	
<b>Pressure</b>	
<b>Wind speed</b>	
<b>Relative humidity</b>	
<b>Last mass determined</b>	
<b>New mass</b>	
<b>Difference between last mass determined and new mass</b>	
<b>Difference x quotient from No. 2</b> <i>(answer is the evaporation rate per square meter)</i>	
<b>Evaporation rate/time in hours since last measurement</b> <i>(answer is the pan evaporation rate per hour)</i>	

- 
-  6. Draw a chart and graph comparing the evaporation rate with each of the following: the local average temperature, pressure, wind speed, and relative humidity for the corresponding period. Use a separate piece of graph paper for each comparison, placing the chart on one side and the graph on the other.

- 
7. Using your graphs, tell if the rate of evaporation changed with an increase of temperature, relative humidity, wind speed, or pressure? If the rate did change, explain how.



- 
8. Was there a difference between day and night evaporation? If so, what was it?



- 
9. When the daily high and low temperatures were closer together, was the evaporation rate greater or smaller? Did you have enough data to evaluate this?



---

**10.** Based on your data, if the global temperatures were to (A) increase or (B) decrease, would you expect the evaporation rate on the Earth's surface to increase, decrease, or stay the same? Why?



---

**11.** If water vapor is a greenhouse gas, what would you expect the addition of more water vapor to the atmosphere to do to global temperature?



---

**12.** Since you are using fresh water, can you expect the ocean (which covers 70 percent of the Earth's surface) to have the same rate of evaporation? What could you do to attempt to determine the evaporation rate of seawater?



## ACTIVITY TWO

# Minimum & Maximum Temperatures & Yearly Temperature Averages

In this exercise, students will look at yearly average temperature data, pick a year that has a lower than average temperature, and examine the specific high/low temperature data for a recording station. This information will be compared to a year that has a higher than average temperature. Pairs of students can be assigned specific years or data sets to analyze and report back to the class. The class results can then be analyzed to see if there is a correlation between a warmer than average year and high/low temperature differential.

### MATERIALS

- Internet access

### PROCEDURE

#### Step 1

Download the graph found at:

[www.ncdc.noaa.gov/images/climate/research/1998/anomalies/triad\\_Pg.gif](http://www.ncdc.noaa.gov/images/climate/research/1998/anomalies/triad_Pg.gif)

#### Step 2

Divide the class into teams of two students. Have teams select (or assign) a year to investigate based on the data in the graph (ie., either higher or lower than average temperatures). They should then select four to five geographic areas of the United States to analyze temperature variations within those areas. If you are teaching several sections, you might have each class pick a year and then the teams would select a location (or vice versa). Each group should write their selection on the ***Student Activity Two Lab Sheet***. (NOTE: Some stations will not have data for all years; make sure your chosen stations have all the necessary data for the time period selected.)

#### Step 3

Go to the Internet site and find the appropriate state and year.

- Go to:  
[www.ncdc.noaa.gov/onlineprod/drought/xmgr.html](http://www.ncdc.noaa.gov/onlineprod/drought/xmgr.html).
- Bookmark this page.
- Click on "National Weather Service Summary of the Day, Time Series."
- Click on "Display Two Parameters for One Station for One Month."
- Select a state.
- Click on "Continue to Next Page."

#### Step 4

Find the appropriate station and record data.

- Select a station.
- Select the variables: (A) "Daily Maximum Temperature" and (B) "Daily Minimum Temperature." (NOTE: Again, remember that some stations will not have data in all years; make sure your chosen stations have all the necessary data for the time period selected.)
- Enter the year and month the team has chosen (conform data acquisition to your student resources).
- For Graphing options click on "Both parameters on same graph."
- For Output format select "GIF."
- Click on "Submit Graph Values."
- Print out the graph and attach to the ***Student Activity Two Lab Sheet***.

#### Step 5

Have students calculate the average daily high temperature, low temperature, and difference between high and low temperature, and record their answers.

#### Step 6

Go back to the selection page and change the variables to: (A) "Maximum relative humidity" and (B) "Minimum relative humidity" and repeat the procedure. Repeat Step 4 and Step 5 and record all data.

**Step 7**

Have students share their information with the class. Use this shared information to answer Questions 4–7 on the *Student Activity Two Lab Sheet*.

**CONCLUSION**

- Have the students predict what they think happened during missing years (years that have not been investigated).
- Discuss the relationship between the average global temperature and the temperature differential for their locations.
- Have students analyze the results from the *Student Activity Two Lab Sheet*, Question 7.

**EXTENSIONS**

1. Have the students choose new variables and repeat Step 4 (remember there are 16 parameters to choose from). Record all data and make appropriate calculations. Ask students to interpret their results and determine how they can effect global trends.
2. Divide the students into groups of 3 or 4. Have these groups research the effects a lower than average temperature, and a higher than average temperature, could have on the water resources in their state.

---

**Student Activity Two Lab Sheet**  
**MINIMUM & MAXIMUM TEMPERATURES & YEARLY TEMPERATURE AVERAGES**

---

**Names**

*Answer the following questions in complete sentences where appropriate. Show ALL work and include ALL labels:*

---

**1.** Selected year and location:



Does selected year and location have a higher or lower than average temperature?

---

**2.** Calculate average daily high temperature, low temperature, and difference between high and low temperature for your specific year and location.



- 
3. Calculate average daily high relative humidity, low relative humidity, and difference between high and low relative humidity.



- 
4. Did years with an increase in average global temperature result in a decrease in temperature differential for a specific location?





---

5. Was there a difference in the results from geographic area to area?



---

6. Looking at the graphs, does it appear that there are larger temperature swings in years with warmer than average temperature or years with cooler average temperatures?



---

7. Take the data compiled by each team and average the information. Do any trends emerge?



## ACTIVITY THREE

# Changes In Salinity Due To Glacier Movement

This activity requires construction of a simple salinity tester, which, for purposes of this exercise, does not need to be calibrated to an established standard. You will, however, be able to make your own calibration scale during this experiment. Students will look at the change in salinity that would arise if a new freshwater source were suddenly present (see "Hubbard Glacier," at the Web site provided on the next page). Damming action could be the result of climate variability and change where glaciers might be advancing due to localized climatic change.

### MATERIALS

- DC milliamperemeter (0 to 100 milliamperes)
- 2 "D" cell battery holder
- Bronze sheeting
- Hook-up wire (#18 solid)
- Salt
- De-ionized water (at least a few liters)
- Stream table
- Computers with Internet access

### CONSTRUCTION OF SALINITY TESTER

These are general guidelines and can be modified. If you do not have bronze foil, you can use the hook-up wire. Remove about 2 centimeters of insulation from the end of the wires. These will become one of the electrodes that will be put in the solutions. Construct the tester as shown in Figure 1.

### TEST SOLUTION

Prepare a solution that will approximate the salinity of seawater by dissolving 3.5 grams of salt in 96.5 milliliters of de-ionized water.

### PROCEDURE

#### **Step 1**

Have students download or look up online:

*<http://edcwww.cr.usgs.gov/earthshots/slow/tableofcontents>.*

Students should bookmark this page. Instruct them to scroll down the right side of the page and under "Water," click on "Hubbard Glacier, Alaska."

Figure 1. Salinity Tester

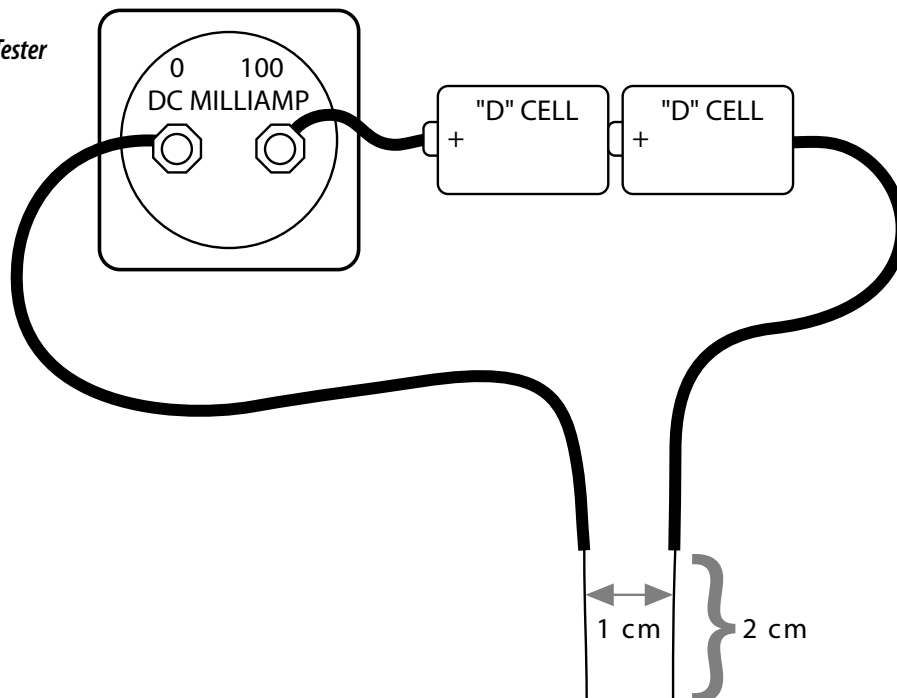

**Step 2**

Have students read the short journal article and look at the maps.

**Step 3**

It is worthwhile to have the class discuss the freshwater/saltwater estuary environment prior to conducting the experiment. In your discussion, note that the article describes three scenarios, with Scenario 2 suggesting the possibility that the change in lake level due to the glacier damming the outlet will reverse the flow of the lake and send it into the headwaters of a creek. Discuss with students that this, in turn, will change the flow rate and estuary salinity balance. Also point out that the river has commercial value for steelhead trout and that the added water will jeopardize the cultural, economic, and environmental use of the land.

**Step 4**

Set up the meter and put the electrodes into the de-ionized water. There should be little or no reading. This will be the fresh water reading. Record the reading, and all other information, on the *Student Activity Three Lab Sheet*.

**Step 5**

Put the electrodes into the “sea water” and measure the current flowing through it. This will be the seawater reading. Record the reading.

**Step 6**

Have the class make its own salinity scale by changing the concentrations and recording the readings in milliamperes. Then make a conversion chart for reference (% NaCl in H<sub>2</sub>O per milliampere).

**Step 7**

Set up the stream table and pool an “ocean” of salt water on one end. You could model the Hubbard Glacier region for extra realism.

**Step 8**

In the estuary region of the “river,” set up the salinity tester. Begin a small flow rate of deionized water, and record the changes. The ocean should have moderate agitation to simulate the normal mixing of the estuary.

**Step 9**

Increase the flow rate, simulating the increased river flow as a result of the damming of the Russell Fjord’s normal outlet, and record the fluctuations in the readings.

**Step 10**

Have students now focus on the types of organisms that live in this region. Ask them to research (in the library and/or on the Internet) and make a hypothetical case for an organism that requires a specific salinity for a portion of its life cycle. Determine the flow rate that will interrupt the cycle, and predict what will happen to this organism.

**Step 11**

Assume that the determined flow rate occurs and the organism is effected. Look at the effects this will have on other species that:

- Depend on that organism to limit their own population.
- Use that organism as their principal food source.

**CONCLUSION**

- Discuss with the students how the change in river flow effected the freshwater/saltwater estuary environment they created.
- Ask the students to predict what this type of change would do to a real estuary environment.
- Discuss how these changes would affect local ecosystems.

**EXTENSION**

1. Have students research freshwater/saltwater estuary environments like the Hubbard Glacier. What long-term effects would they expect to find if damming occurred? Has this happened in other regions? If so, where? What were the outcomes?
2. Have students consider the potential effects of evaporation on ocean water salinity. How would they modify the experiment to take evaporation into account? How would their results differ? Try the experiment.

---

**Student Activity Three Lab Sheet**  
**CHANGES IN SALINITY DUE TO GLACIER MOVEMENT**

---

Name \_\_\_\_\_

*Answer the following questions in complete sentences where appropriate. Show ALL work and include ALL labels:*

---

1. Initial fresh water reading:



---

2. Initial sea water reading:



---

3. a. Salinity scale:



b. Conversion chart (% NaCl in H<sub>2</sub>O per milliampere):

---

4. Changes in reading due to small flow rate:



---

5. Fluctuations in readings due to increased river flow:



---

6. Make a hypothetical case for an organism that requires a specific salinity for a portion of its life cycle. Determine the flow rate that will interrupt the cycle.



---

7. Look at other species that depend on that organism to limit their own population or use that organism as their principal food source. How might the food chain be impacted? How might these impacts effect humans?



## Appendix A

# Bibliography

"Analysis of Trends in the U.S. and the Former U.S.S.R. Pan Evaporation"  
[www.ncdc.noaa.gov/ol/climate/research/ogp/papers/peterso2.htm](http://www.ncdc.noaa.gov/ol/climate/research/ogp/papers/peterso2.htm)

CLIMVUS  
[www.ncdc.noaa.gov/onlineprod/drought/xmgr.html](http://www.ncdc.noaa.gov/onlineprod/drought/xmgr.html)

Global Temperature (meteorological stations)  
<http://www.giss.nasa.gov/research/observe/surftemp/1998.fig1.GIF>

"Global Warming" (a starting point for discussions on global warming, greenhouse gases, the hydrologic cycle, and natural variability)  
[www.ncdc.noaa.gov/ol/climate/globalwarming.html#INTRO](http://www.ncdc.noaa.gov/ol/climate/globalwarming.html#INTRO)

Irrigation Scheduling: Evaporation Pans Still Work!  
<http://www.montana.edu/~wwwpb/ag/bauder21.html>

July Global Surface Mean Temperature Anomalies  
[http://www.ncdc.noaa.gov/images/climate/research/1998/anomalies/triad\\_Pg.gif](http://www.ncdc.noaa.gov/images/climate/research/1998/anomalies/triad_Pg.gif)

Pan Evaporation Decreases  
<http://www.ncdc.noaa.gov/ol/climate/research/ogp/papers/peterso2.html>

Temperature Anomaly (°C)  
<http://www.giss.nasa.gov/research/observe/surftemp/1998.fig2.GIF>

USGS Earthshots  
<http://edcwww.cr.usgs.gov/earthshots/slow/tableofcontents>  
<http://edcwww.cr.usgs.gov/earthshots/slow/Hubbard/Hubbardtext>  
<http://edcwww.cr.usgs.gov/earthshots/slow/Hubbard/PERSpaper1985>

Maximum and Minimum Temperature Trends for the Globe  
<http://www.sciencemag.org/cgi/content/abstract/277/5324/364>

# Assessment Rubrics & Answer Key

## Assessment Rubric: ACTIVITY ONE

SKILL	Excellent (4)	Good (3)	Satisfactory (2)	Needs Improvement (1)
<b>Able to make accurate calculations.</b>	Able to make accurate calculations.	Able to make calculations, but makes careless mistakes.	Able to make some calculations.	Not able to make calculations.
<b>Able to collect data that is accurate.</b>	Collects data that is accurate.	Able to collect data, most of which is accurate.	Able to collect data, some of which is accurate.	Collects inaccurate data.
<b>Represents data clearly on graph.</b>	Data is represented clearly on graph.	Data is represented, but graphs do not have a polished look.	Data is missing from graphs.	Data is missing and graphs are poorly done.
<b>Able to determine relationships between data.</b>	Able to determine many relationships between data.	Able to determine some relationships between data.	Able to determine relationships with guidance.	Not able to determine relationships.
<b>Infers links between data and global conditions.</b>	Able to infer many links.	Able to infer some links.	Able to infer links with guidance.	Not able to infer links.
<b>Provides logical answers to questions.</b>	All answers are logical.	Provides many answers, most are logical.	Provides few logical answers.	Answers provided are not logical.
<b>Participates in class discussions.</b>	Always participates.	Participates frequently.	Rarely participates.	Does not participate.



## Assessment Rubric: ACTIVITY TWO

<b>SKILL</b>	<b>Excellent (4)</b>	<b>Good (3)</b>	<b>Satisfactory (2)</b>	<b>Needs Improvement (1)</b>
<b>Able to access relevant information at appropriate Internet sites.</b>	Able to access relevant information from appropriate Internet sites.	Accesses some relevant information from appropriate Internet sites.	Accesses very little relevant information at a few appropriate Internet sites.	Accesses irrelevant information from Internet sites.
<b>Demonstrates ability to make accurate calculations.</b>	Able to make accurate calculations.	Able to make calculations, but makes careless mistakes.	Able to make some calculations.	Not able to make calculations.
<b>Infers links among global and regional data.</b>	Able to infer many links.	Able to infer some links.	Able to infer links with guidance.	Not able to infer links.
<b>Able to analyze data/graphs.</b>	Able to make an in-depth, insightful analysis.	Able to make an accurate, but general analysis.	Provides a logical but poor analysis.	Provides an illogical analysis.
<b>Able to interpret trends.</b>	Able to make an in-depth interpretation.	Able to make a complete, but general interpretation.	Provides an incomplete interpretation.	Provides an incorrect interpretation.
<b>Provides logical answers to questions.</b>	All answers are logical.	Provides many answers, most are logical.	Provides few logical answers.	Answers provided are not logical.
<b>Participates in class discussions.</b>	Always participates.	Participates frequently.	Rarely participates.	Does not participate.

### Assessment Rubric: ACTIVITY THREE

SKILL	Excellent (4)	Good (3)	Satisfactory (2)	Needs Improvement (1)
<b>Able to accurately read equipment.</b>	Able to accurately read equipment.	Reads equipment with some mistakes.	Reads equipment with many mistakes.	Not able to read equipment.
<b>Able to make accurate calculations.</b>	Able to make accurate calculations.	Able to make calculations, but makes careless mistakes.	Able to make some calculations.	Not able to make calculations.
<b>Research and summarize data.</b>	Conducts in-depth research and provides a detailed summary.	Conducts adequate research and provides a good summary.	Conducts adequate research and provides a poor summary.	Conducts inadequate research and provides a poor summary.
<b>Determine relationship between an organism and its environment.</b>	Determines an in-depth and insightful relationship.	Determines an in-depth relationship.	Determines a vague but logical relationship.	Provides an illogical relationship.
<b>Analyze the effects changes will have on the environment.</b>	Forms a detailed and insightful analysis of many effects.	Forms a good analysis of many effects.	Forms a good analysis of a few effects.	Forms a poor analysis of a few effects.
<b>Provides logical answers to questions.</b>	All answers are logical.	Provides many answers, most are logical.	Provides few logical answers.	Answers provided are not logical.
<b>Participates in class discussions.</b>	Always participates.	Participates frequently.	Rarely participates.	Does not participate.

### Answer Key: STUDENT ACTIVITY LAB SHEETS

Answers will vary due to the uniqueness of each set-up, search, or organism.  
Review all answers carefully for accuracy.

# National Education Standards

***This activity responds to the following National Education Standards:***

## **STANDARDS FOR THE ENGLISH LANGUAGE ARTS**

**Standard 3:** Students apply a wide range of strategies to comprehend, interpret, evaluate, and appreciate texts. They draw on their prior experience, their interactions with other readers and writers, their knowledge of word meaning and of other texts, their word identification strategies, and their understanding of textual features (e.g., sound-letter correspondence, sentence structure, context, graphics).

**Standard 4:** Students adjust their use of spoken, written, and visual language (e.g., conventions, style, vocabulary) to communicate effectively with a variety of audiences and for different purposes.

**Standard 5:** Students employ a wide range of strategies as they write and use different writing process elements appropriately to communicate with different audiences for a variety of purposes.

**Standard 6:** Students apply knowledge of language structure, language conventions (e.g., spelling and punctuation), media techniques, figurative language, and genre to create, critique, and discuss different print and non-print texts.

**Standard 7:** Students conduct research on issues and interests by generating ideas and questions, and by posing problems. They gather, evaluate, and synthesize data from a variety of sources (e.g., print and nonprint texts, artifacts, people) to communicate their discoveries in ways that suit their purpose and audience.

**Standard 8:** Students use a variety of technological and informational resources (e.g., libraries, databases, computer networks, video) to gather and synthesize information and to create and communicate knowledge.

**Standard 12:** Students use spoken, written, and visual language to accomplish their own purposes (e.g., for learning, enjoyment, persuasion, and the exchange of information).

*National Council of Teachers of English and International Reading Association. 1996. **Standards for the English Language Arts** p. 24–46. Urbana, Illinois and Newark, Delaware: National Council of Teachers of English and International Reading Association.*

## **NATIONAL GEOGRAPHY STANDARDS GEOGRAPHY FOR LIFE**

### **GEOGRAPHY STANDARDS: 5–8**

**Geography Standard 1:** *The World in Spatial Terms.* How to use maps and other geographic representations, tools, and technologies to acquire, process, and report information from a spatial perspective.

**Geography Standard 7:** *Physical Systems.* The physical processes that shape the patterns of Earth's surface.

**Geography Standard 8:** *Physical Systems.* The characteristics and spatial distribution of ecosystems on Earth's surface.

**Geography Standard 15:** *Environment and Society.* How physical systems affect human systems.

**Geography Standard 18:** *The Uses of Geography.* How to apply geography to interpret the present and plan for the future.

*American Geographical Society, Association of American Geographers, National Council for Geographic Education, and National Geographic Society. 1994. **Geography for Life: National Geography Standards** p. 143–182. Washington, DC: National Geographic Research and Exploration.*

### **GEOGRAPHY STANDARDS: 9–12**

**Geography Standard 1:** *The World in Spatial Terms.* How to use maps and other geographic representations, tools, and technologies to acquire, process, and report information from a spatial perspective.

**Geography Standard 7: Physical Systems.**

The physical processes that shape the patterns of Earth’s surface.

**Geography Standard 8: Physical Systems.**

The characteristics and spatial distribution of ecosystems on Earth’s surface.

**Geography Standard 15: Environment and Society.** How physical systems affect human systems.

**Geography Standard 18: The Uses of Geography.** How to apply geography to interpret the present and plan for the future.

*American Geographical Society, Association of American Geographers, National Council for Geographic Education, and National Geographic Society. 1994. Geography for Life: National Geography Standards p. 183–222. Washington, DC: National Geographic Research and Exploration.*

**CURRICULUM AND EVALUATION STANDARDS FOR SCHOOL MATHEMATICS**

**CURRICULUM STANDARDS: 5–8**

**Standard 1:** Mathematics as problem solving.

**Standard 2:** Mathematics as communication.

**Standard 3:** Mathematics as reasoning.

**Standard 4:** Mathematical connections.

**Standard 5:** Number and number relationships.

**Standard 7:** Computation and estimation.

**Standard 8:** Patterns and functions.

**Standard 9:** Algebra.

*National Council of Teachers of Mathematics. 1989. Curriculum and Evaluation Standards for School Mathematics p. 65–119. Reston, VA: The National Council of Teachers of Mathematics, Inc.*

**CURRICULUM STANDARDS: 9–12**

**Standard 1:** Mathematics as problem solving.

**Standard 2:** Mathematics as communication.

**Standard 3:** Mathematics as reasoning.

**Standard 4:** Mathematical connections.

**Standard 5:** Algebra.

*National Council of Teachers of Mathematics. 1989. Curriculum and Evaluation Standards for School Mathematics p. 123–186. Reston, VA: The National Council of Teachers of Mathematics, Inc.*

**NATIONAL SCIENCE EDUCATION STANDARDS**

**CONTENT STANDARD: K–12**

**Unifying Concepts and Processes**

**Standard:** As a result of activities in grades K–12, all students should develop understanding and abilities aligned with the following concepts and processes:

- Systems, orders, and organization
- Evidence, models, and explanation
- Constancy, change, and measurement

*National Research Council. 1996. National Science Education Standards p. 115–119. Washington, DC: National Academy Press.*

**CONTENT STANDARDS: 5–8**

**Science as Inquiry**

**Content Standard A:** As a result of activities in grades 5–8, all students should develop:

- Abilities necessary to do scientific inquiry
- Understandings about scientific inquiry

**Physical Science**

**Content Standard B:** As a result of activities in grades 5–8, all students should develop an understanding of:

- Properties and changes of properties in matter
- Transfer of energy

**Life Science**

**Content Standard C:** As a result of activities in grades 5–8, all students should develop an understanding of:

- Structure and function in living systems
- Regulation and behavior
- Populations and ecosystems

### Earth and Space Science

**Content Standard D:** As a result of activities in grades 5–8, all students should develop an understanding of:

- Structure of the Earth system

### Science and Technology

**Content Standard E:** As a result of activities in grades 5–8, all students should develop:

- Abilities of technological design
- Understandings about science and technology

### Science in Personal and Social Perspectives

**Content Standard F:** As a result of activities in grades 5–8, all students should develop an understanding of:

- Natural hazards
- Risks and benefits
- Science and technology in society

*National Research Council. 1996. National Science Education Standards p. 143–171. Washington, DC: National Academy Press.*

## CONTENT STANDARDS: 9–12

### Science as Inquiry

**Content Standard A:** As a result of activities in grades 9–12, all students should develop:

- Abilities necessary to do scientific inquiry
- Understandings about scientific inquiry

### Life Science

**Content Standard C:** As a result of activities in grades 9–12, all students should develop an understanding of:

- Interdependence of organisms
- Matter, energy, and organization in living systems
- Behavior of organisms

### Earth and Space Science

**Content Standard D:** As a result of activities in grades 9–12, all students should develop an understanding of:

- Energy in the Earth system
- Geochemical cycles

### Science and Technology

**Content Standard E:** As a result of activities in grades 9–12, all students should develop:

- Abilities of technological design
- Understandings about science and technology

### Science in Personal and Social Perspectives

**Content Standard F:** As a result of activities in grades 9–12, all students should develop an understanding of:

- Natural resources
- Natural and human-induced hazards
- Science and technology in local, national, and global challenges

*National Research Council. 1996. National Science Education Standards p. 173–204. Washington, DC: National Academy Press.*

## CURRICULUM STANDARDS FOR SOCIAL STUDIES

**Strand 3: People, Places, & Environments.** Social studies programs should include experiences that provide for the study of people, places, and environments.

**Strand 8: Science, Technology, & Society.** Social studies programs should include experiences that provide for the study of relationships among science, technology, and society.

**Strand 9: Global Connections.** Social studies programs should include experiences that provide for the study of global connections and interdependence.

*National Council for the Social Studies. 1994. Expectations of Excellence: Curriculum Standards for the Social Studies p. 21–30. Washington, DC: National Council for the Social Studies.*

# Associated Lab Exercises

The following lab exercises can be used for developing background relationships to help students understand the preceding exercises.

## LAB 1

### Specific Heat

#### INTRODUCTION

In this lab we will look at the energy required to change the temperature of various substances. It has been observed by many of you, I'm sure, that different substances require more energy to raise their temperature. (Pick up a cold metal knife from a drawer and a plastic one; which reaches the temperature of your hand first?) We will attempt to quantify this relationship in this experiment.

#### BACKGROUND

The specific heat of a substance is defined as the number of calories required to raise 1 gram of a substance 1 degree centigrade. Since the calorie is a unit of heat and it is defined as the amount of heat required to raise 1 gram of pure water one degree centigrade, it follows that the specific heat of water is 1.

So if you want to know how many calories of heat a quantity of water has gained, all you need to know is the mass of the water and the change in temperature of the water.

Remember that: **1 ml = 1 cc = 1 gr of H<sub>2</sub>O**

OR:

**(1) Heat gain in water** = mass of water x specific heat of water x change in water temperature

This relationship is very helpful. Since energy is neither created or destroyed but can be transferred, we can assume that the change in temperature of a body of water when a hot object is added to it is the result of the energy in the hot object being transferred to the cooler water. (Until the water and the object reach equilibrium.) We can further assume that if it is a closed system (no other energy can get in or out), that the heat gained by the water is equal to the heat lost by the hot object. Again, the energy in the object is transferred to the water until equilibrium is reached.

OR:

**Heat gained by water** = heat lost by object

SO:

**Heat lost by object** = mass of object x specific heat of object x change in object's temperature

Then solving for specific heat we get:

**Heat loss by object**

mass of object x change in object's temperature = specific heat of object

Since the heat lost by the object is equal to the heat gained by the water, you get:

**(2) Heat gained by water**

mass of object x change in object's temperature = specific heat of object

**MATERIALS**

Styrofoam calorimeters; calibrated thermometers; large beaker for boiling water; room temperature tap water; various objects for testing (include metallic cylinders); hot plate; balance; graduated cylinder; and a ring stand.

**PROCEDURE**

1. Make several calorimeters by placing one styrofoam cup inside the other, then cut about 2" off the rim of a third cup and turn it upside down into the two cup base. Poke a small hole in the top of the inverted cup for the thermometer .
2. Determine the mass of the objects and record.
3. Bring a beaker of water to a boil and suspend the objects in the water. (You want the objects to get their heat from the water, not by resting on the glass.)
4. Be sure all thermometers are calibrated in the boiling water; this is your starting point for the objects' initial temperature.
5. Fill each calorimeter with 100 ml of tap water and record the temperature.
6. Take an object out of the boiling water and immediately place in the calorimeter; record the maximum temperature the water achieves.
7. Time the interval between adding the object and equilibrium was reached; record.
8. Using formulas (1) and (2), calculate the heat gained by the water and then the object's specific heat.

**DATA**

Object	Mass in Grams	Initial Temperature of Object in °C	Initial Temperature of Calorimeter in °C	Maximum Temperature of Calorimeter in °C	Time	Heat Gained by Water	Specific Heat of Object

## ■ QUESTIONS

Did all objects have the same specific heat?

Calculate the density of the objects; was there a correlation between the specific heat and their density?

Did the objects that had higher specific heats reach equilibrium faster or slower than objects with lower values?

What can you say about the specific heat of a material and its ability to absorb and lose heat?

With respect to the Earth, what materials on the surface of the Earth would be best in absorbing and releasing energy from the sun?



## LAB 2

### Investigating the Effects of the Different Specific Heat of Earth's Materials

#### INTRODUCTION

In this lab you will explore the ability of various substances on the Earth to absorb and radiate energy.

#### MATERIALS

Five thermometers; four 100 ml beakers; three ring stands with five thermometer holders; room temperature tap water and some soil (dry); stop watch; and a 100 watt bulb on exposed lamp clamp.

#### PROCEDURE

- Place the thermometers in a water bath and allow them to stabilize.
- Label the thermometers and their readings. This will allow you to compensate for the discrepancies between thermometer readings. To do this, find the thermometer with the lowest reading and then label all the other thermometers with the difference in degrees from the lowest one. The reading from those thermometers will be compensated by subtracting the discrepancy reading from the recorded temperature.
- Fill one beaker with 100 ml of room temperature soil. Fill another beaker with 100 ml of room temperature water and fill a third beaker with 100 ml of moist soil.
- Set up the lamp so it is about 2" above lab table facing down. Arrange beakers in a circle about 10 cm from the surface of the bulb. Set up ring stands so one stand will be able to hold two thermometers; one thermometer will be placed 2 cm below the surface of the materials in the beakers. For the beaker filled with air, maintain the same relative height as the other thermometers; attempt to shield the thermometer bulb from the direct infrared rays of the bulb by forming a small shield out of tinfoil around the base. It has not been found necessary to

do this with the water. The control thermometer should be placed the same distance and height from the bulb as the rest of the thermometers.

- Record all thermometer readings.
- Turn on the light, start the stopwatch, and record the temperature every minute (for at least 10 minutes). Turn off the light and (remove) continue to record the temperature every minute until they return to original ambient temperature (time permitting).

#### ANALYSIS

From your data chart, construct a graph showing the change in temperature with respect to time. Plot all materials on the same graph and use a different color for each material tested.

#### QUESTIONS

- Which substance gained heat fastest?
- Which substance was slowest to gain heat?
- Which substance lost heat fastest?
- Which substance was the slowest to lose heat?
- Which substance had the smallest change in temperature?
- Which substance had the greatest change in temperature?

#### SPECULATIVE QUESTIONS

What does the data allow you to speculate about incoming insolation and the Earth's ability to absorb and retain energy?

If you add water to the atmosphere, what changes to global energy transport do you think could result?

## LAB 3

### Conservation of Energy and Phase Changes of Water

#### INTRODUCTION

Water is the primary energy mover on our Earth. In our atmosphere and oceans, water's high specific heat allows it to transport heat. The distance both liquid and gaseous water transports heat can be great and is a function of:

- Winds and air temperature, when dealing with water vapor.
- Ocean currents and the temperature of the atmosphere overlying it, and the waters surrounding and mixing with it, when dealing with liquid water.

In this exercise we will look at the energy absorbed by water needed to effect phase changes. Remember, water must be in the liquid or gas state in order to effectively move the energy that the Earth receives from insolation. The primary method of transport is convection.

#### TERMS

Water vapor  
Conduction  
Convection  
Radiation  
Calorie  
Latent heat  
Melting  
Vaporization

#### MATERIALS

Bunsen burner; ring stand with wire screen; 250 ml beaker; ice; water; thermometer; stopwatch.

#### PROCEDURE

1. Calibrate the thermometer, then set up the ring stand so the beaker will be just below the top of the Bunsen flame.
2. Start the Bunsen burner and adjust the flame.

3. Put 150 ml of ice in the beaker and add 50 ml of water.
4. Begin stirring the water and ice and when it reaches the lowest temperature, record the temperature on the chart.
5. Next place the beaker on the ring stand and start the stopwatch simultaneously. Begin recording the temperature every 30 seconds for at least 10 minutes.
6. Note the time when the ice begins to melt, when all the ice is gone, and when the water begins to boil.
7. Graph the data, placing the temperature on the vertical axis and the time on the horizontal. Mark the points where the water was changing phase.

#### QUESTIONS

According to your graph, did the temperature change during the phase changes?

When was the temperature change most rapid? (Refer to the slope of your graph.)

If the Bunsen burner output was constant, what can you infer about the absorption of energy by the water?

Which phase change required the most energy to achieve?

What can you infer about the release of energy by the water when it reverses the direction of phase change? (Vapor to liquid to gas.)

**DATA**

TIME:			TIME:			TIME:		
Min.	Sec.	Temp. °C	Min.	Sec.	Temp. °C	Min.	Sec.	Temp. °C
0	0		7	30		15	0	
0	30		8	0		15	30	
1	0		8	30		16	0	
1	30		9	0		16	30	
2	0		9	30		17	0	
2	30		10	0		17	30	
3	0		10	30		18	0	
3	30		11	0		18	30	
4	0		11	30		19	0	
4	30		12	0		19	30	
5	0		12	30		20	0	
5	30		13	0		20	30	
6	0		13	30		21	0	
6	30		14	0		21	30	
7	0		14	30		22	0	

*Chart can be extended if needed; however, usually 20 minutes is sufficient.*

# Information Associated With Activity Three

## TEST SOLUTION

Prepare a solution that will approximate the salinity of sea water. Dissolve 3.5 grams of salt in 96.5 ml of de-ionized water.

## PROCEDURE

You will look at the change in salinity that would arise if a freshwater source was suddenly present. (See Hubbard.) The damming action could be the result of global environmental change where glaciers might be advancing due to localized climatic change.

Download or look up online:

[http://edewww.cr.usgs.gov/earthshots/slow/table\\_of\\_contents](http://edewww.cr.usgs.gov/earthshots/slow/table_of_contents)

(Bookmark this page.) Scroll down the right side of the page and under "Water," click on "Hubbard Glacier, Alaska." Read the article and look at the maps. Discussion about the fresh/saltwater estuary environment prior to the experiment is worthwhile. The paper has three scenarios. Scenario number 2 has the possibility that the change in lake level due to the glacier damming the outlet will reverse the flow of the lake and send it into the headwaters of a creek. This will in turn change the flow rate and estuary salinity balance. This river has a commercial value for steelhead trout, and the added water will also jeopardize the cultural, economic, and environmental use of the land.

After the discussion, set up the meter and put the electrodes into the de-ionized water. There should be little to no reading. Next, measure the current flowing through the "sea water." You now have your fresh and sea water readings. You can make your own salinity scale by changing the concentrations and recording the readings in ma (milliamperes). A conversion chart can be made for reference (% NaCl in H<sub>2</sub>O per ma).

Set up the stream table and "pool" an ocean on one end. You could model the Hubbard region for extra realism. In the estuary region of the river, set up the salinity tester to begin a small flow rate and record the changes. (The "ocean" should have moderate agitation to simulate the normal mixing of the estuary.) Next, increase the flow rate simulating the increased flow of the river due to the damming of the Russell Fjord's normal outlet. Record the fluctuations in the readings. Make a hypothetical case for an organism that requires a specific salinity for a portion of its life cycle. Determine the flow rate that will interrupt the cycle. Next, look at the other species that depend on that particular organism to limit their own populations or use that organism for their principle source of food. What results in the food chain might result? How could it impact humans?

**INSTITUTE**  
*for* **GLOBAL**  
**ENVIRONMENTAL**  
**STRATEGIES**

1600 Wilson Boulevard  
Suite 901  
Arlington, VA 22209

---

*This material is based upon work supported  
by NASA under grant No. NAG5-6974.*